

WOODCREST MFG.

150 WASHINGTON AVE. P.O. BOX 848 PERU, IN. 46970 PHONE# 765-472-4471

TOOLS REQUIRED

7/16" SOCKET OR NUT DRIVER
PHILLIPS HEAD SCREWDRIVER
HAMMER

INSTRUCTIONS FOR F62 RAIL PKG.

WOODCREST BUNK BEDS

MODEL # F62 FUTON/BUNK BED ASSEMBLY INSTRUCTIONS

PARTS	QUANTITY
A. 1/4" FLAT WASHERS	16
B. 3 1/2" LAG BOLTS *	16
C. #14 X 3/4" SCREWS	4
D. #10 X 2" SCREWS	14
E. SAFETY WIRES	2
F. 3" DOWELS	4
G. BACK DECK	1
H. SEAT DECK	1
I. 3" BOLTS	4
J. WASHERS	4
K. 1/4" NUTS	4
L. 1/4" TEE NUTS	16

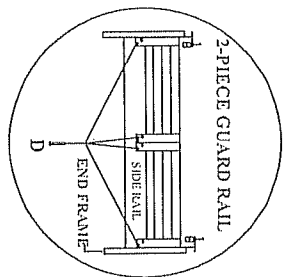

IF THE BUNK BED WILL BE PLACED NEXT TO A WALL, THE GUARD RAIL THAT RUNS THE FULL LENGTH OF THE BED SHOULD BE PLACED AGAINST THE WALL TO PREVENT ENTRAPMENT BETWEEN THE BED AND THE WALL.

*NOTE: WHEN USING T/NUTS, THE 3 1/2" LAG BOLTS WILL BE REPLACED BY 4" MACHINE BOLTS.

SIZE OF MATTRESS AND FOUNDATION

THIS BED IS DESIGNED TO USE A MATTRESS (37 1/2" X 74") AND BUNKIE BOARD (37 1/2" X 74"). THE TOTAL THICKNESS MUST NOT EXCEED 8" ON UPPER AND LOWER BUNKS ON ALL MODELS EXCEPT THE 2400 AND THE MATTRESS MUST NOT EXCEED 7" ON UPPER AND LOWER BUNKS.

NOTE: THERE MUST BE AT LEAST 5" FROM MATTRESS SLEEPING SURFACE TO TOP EDGE OF GUARD RAIL.

REPLACEMENT PARTS

REPLACEMENT PARTS, INCLUDING ADDITIONAL GUARD RAILS, MAY BE OBTAINED FROM ANY OF OUR WOODCREST DEALERS.

1) SIDE RAILS- POSITION SIDE RAILS TO LOWER END FRAME WITH FOUNDATION BLOCKS TURNED INSIDE AND DOWN. ASSEMBLE WITH LAG BOLTS (B) AND FLAT WASHERS (A). REPEAT FOR UPPER BED FRAME. NOTE: LOWER FRAME HAVE HOLES DRILLED TO ATTACH METAL FUTON MECHANISM. HOLES WITH "BACK" STAMP GOES CLOSEST TO WALL.

2) STACK BED- PLACE STACKING DOWEL (E) IN DOWEL HOLES ON LOWER BED. CAREFULLY PLACE UPPER BUNK ON DOWELS MAKING SURE ALL HOLES ARE PROPERLY ALIGNED.

3) ATTACH RIGHT AND LEFT FUTON MECHANISM USING HARDWARE (I, J, K.) PROVIDED IN RAIL RAIL PACKAGE. WHEN FACING BED, WITH HOLES STAMPED "BACK" ARE FARTHEST AWAY FROM YOU, MECHANISM STAMPED "L" GOES ON THE LEFT AND "R" GOES ON THE RIGHT. PLACE THE 2" BOLTS (I) AND WASHER (J) THROUGH THE HOLES IN THE END FRAME AND THE METAL DECK. MECHANISM AND TIGHTEN WITH 1/4" NUTS (K).

4) USING HARDWARE AND INSTRUCTIONS PROVIDED WITH METAL DECK, AFFIX METAL DECK TO THE METAL MECHANISM USING BLACK BOLTS, WASHERS, LOCK NUTS. NOTE: SEAT DECK HAS TWO HANDLES WHICH FACE UPWARDS DURING ASSEMBLY.

5) SAFETY WIRES- POSITION WIRES (E) ON THE TOP OF THE FOUNDATION BLOCKS 1 1/2" FROM THE INSIDE OF THE END STRUCTURE. ASSEMBLY WITH 14 X 3/4" SCREWS (C). NOTE: WIRES ARE A SAFETY FEATURE TO PREVENT THE MATTRESS FROM FALLING BETWEEN THE FOUNDATION BLOCKS. WIRES ARE NOT TO BE USED AS FOUNDATION.

6) GUARD RAILS- POSITION GUARD RAIL AT THE CENTER OF THE UPPER SIDE RAIL ON THE FRONT SIDE AND ASSURE THERE IS NO MORE THAN 15" FROM THE END OF THE GUARD RAIL TO BED END STRUCTURE. PLACE TWO PIECE GUARD RAIL ON THE BACK SIDE RAIL LEAVING A 1/8" GAP BETWEEN GUARD RAIL AND BED END STRUCTURE. ASSEMBLE WITH #10 X 2" SCREWS (D).

****BUNK BEDS THAT LAST MADE IN THE U.S.A.****

WOODCREST MFG.

WOODCREST CERTIFIES

THIS BUNK BED MODEL HAS BEEN TESTED BY AN INDEPENDENT LABORATORY AND IS IN COMPLIANCE WITH ASTM F-1427 STANDARD CONSUMER SAFETY SPECIFICATION FOR BUNK BEDS AND CODE OF FEDERAL REGULATIONS (CFR) 1213 "SAFETY STANDARDS FOR ENTRAPMENT HAZARDS IN BUNK BEDS"

AND CODE (CFR) 1513

REQUIREMENTS FOR BUNK BEDS"

* * * * *

MADE IN U.S.A.
BUY AMERICAN

SOME EXCESS PARTS MAY BE INCLUDED.

MODELS: F-62

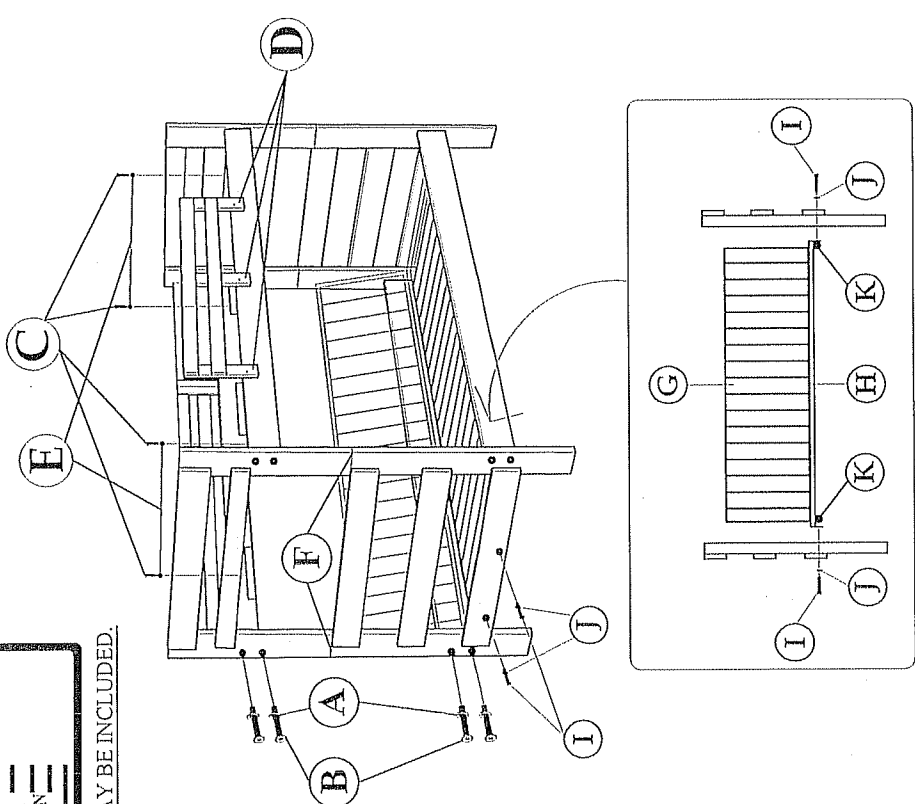
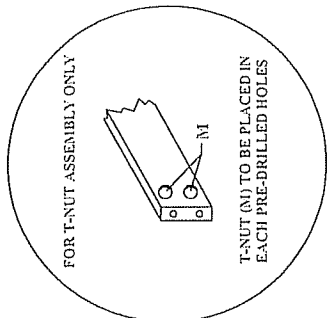



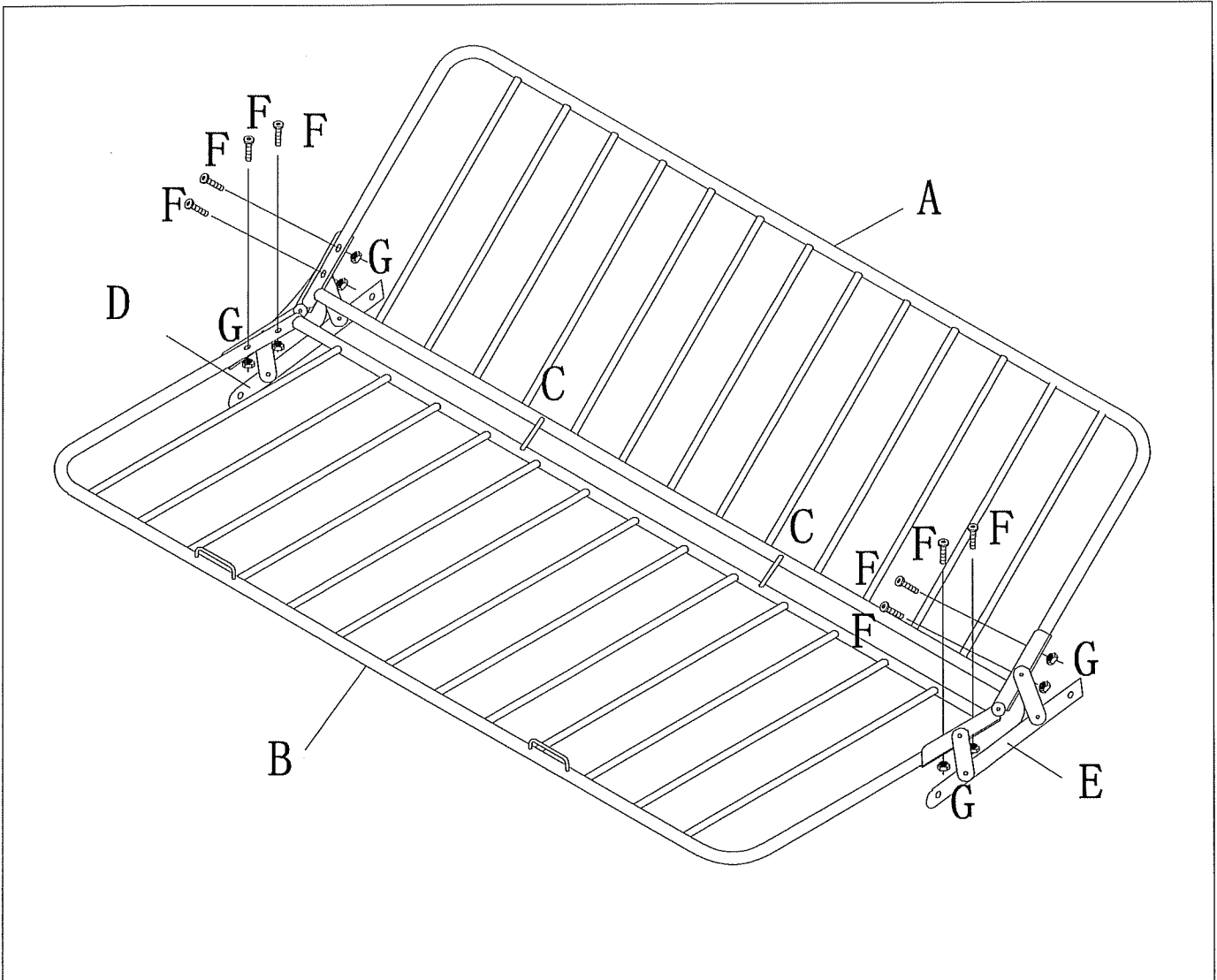

SAFETY WARNINGS

- 1) FOLLOW THE INFORMATION ON THE WARNINGS APPEARING ON THE UPPER BUNK END STRUCTURE AND ON THE CARTON. DO NOT REMOVE WARNING LABEL FROM BED.
 - 2) ALWAYS USE THE RECOMMENDED SIZE MATTRESS OR MATTRESS SUPPORT OR BOTH, TO PREVENT THE LIKELIHOOD OF ENTRAPMENT OR FALLS.
 - 3) SURFACE OF MATTRESS MUST BE AT LEAST 5" BELOW THE UPPER EDGE OF THE GUARDRAILS.
 - 4) DO NOT ALLOW CHILDREN UNDER 6 YEARS OF AGE TO USE THE UPPER BUNK.
 - 5) PERIODICALLY CHECK TO ENSURE THAT THE GUARDRAILS, THE LADDER, AND OTHER COMPONENTS ARE IN THEIR PROPER POSITION. FREE FROM DAMAGE, AND THAT ALL CONNECTIONS ARE TIGHT.
 - 6) DO NOT ALLOW HORSEPLAY ON OR UNDER THE BED AND PROHIBIT JUMPING ON THE BED.
 - 7) ALWAYS USE THE LADDER FOR ENTERING AND LEAVING THE UPPER BUNK.
 - 8) DO NOT SUBSTITUTE PARTS. CONTACT THE MANUFACTURER OR DEALER FOR REPLACEMENT PARTS.
 - 9) USE OF A NIGHTLIGHT MAY PROVIDE ADDED SAFETY. PRECAUTION FOR A CHILD USING THE UPPER BUNK.
 - 10) ALWAYS USE GUARDRAILS ON BOTH LONG SIDE OF UPPER BUNK.
 - 11) THE USE OF WATER OR SLEEP FLOTATION MATTRESS IS PROHIBITED.
 - 12) PROHIBIT MORE THAN ONE PERSON ON THE UPPER BUNK.
 - 13) KEEP THESE INSTRUCTIONS FOR FURTHER REFERENCE.
 - 14) IF THE BUNK BED WILL BE PLACED NEXT TO A WALL THE GUARDRAIL THAT RUNS THE FULL LENGTH OF THE BED SHOULD BE PLACED AGAINST THE WALL TO PREVENT ENTRAPMENT BETWEEN THE BED AND WALL.
- STRANGULATION HAZARD
- 15) NEVER ATTACH OR HANG ITEMS TO ANY PART OF THE BUNK BED THAT ARE NOT DESIGNED FOR USE WITH THE BED FOR EXAMPLE, BUT NOT LIMITED TO HOOKS, BELTS, AND JUMP ROPES.

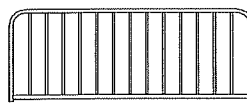
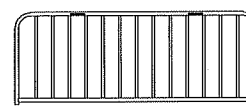
****BUNK BEDS THAT LAST MADE IN THE U.S.A.****

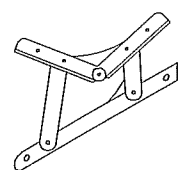
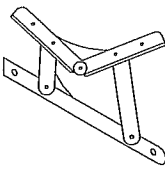
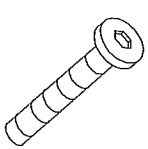

<p>A</p>  <p>1PC</p>	<p>B</p>  <p>1PC</p>	<p>C</p>  <p>2PCS</p>	<p>D</p>  <p>1PC</p>
<p>E</p>  <p>1PC</p>	<p>F</p>  <p>8PCS</p>	<p>G</p>  <p>8PCS</p>	<p>H</p>  <p>I</p> 